

SMARTSCAN INFORMATION



RY4 SERIES SAFETY RELAYS HANDBOOK

Smartsan Ltd, Pywell Road, CORBY, NN17 5XJ, UK, Tel: +44 (0) 1536 401313,
Fax: +44 (0) 1536 268954, Email: sales@smartsan.com, www.smartsan.co.uk

Issue 2

CONTENTS	Page
INTRODUCTION	5
RY4A SAFETY RELAY UNIT 020 – 005	6
RY4B SAFETY RELAY UNIT 020 – 010	12
RY4C SAFETY RELAY UNIT 020 – 015	17
APPENDIX 1	22
APPENDIX 2	23
APPENDIX 3	24
APPENDIX 4	25
APPENDIX 5	26
APPENDIX 6	27



www.smartscan.com

INTRODUCTION

The Smartscan RY4 Series provides dedicated relay output switching options that may be used with the SL 2 series, SL4 series, T4 and T4SG-E series safety light curtains.

In addition the RY4 Series relays have been designed to provide easy connection of the T4SG-E and SL series safety light curtains. The units mirror the T4SG-E and SL series functions and offer a different number of normally open safety contacts for increased flexibility.

The units when used in conjunction with the T4SG-E and SL 4 series are suitable for all applications where the control system is rated as, EN ISO 13849 – 1 PL e and EN 61508 SIL 3. When used with the SL 2 series they are suitable for applications rated as, EN ISO 13849 – 1 PL d and EN 61508 SIL 2.

Model number	Description
020-005	RY4A Safety Relay for T4 Series 2 N/O & 1 N/C
020-010	RY4B Safety Relay for T4 Series 3 N/O & 1 N/C
020-015	RY4C Safety Relay for T4 Series 3 N/O & 1 N/C RJ45 Connection

RY4A – The RY4A provides a simple low cost safety relay output option for the T4 Series.

2 normally open safety relay contacts rated at 250V AC, 6A and 1 normally closed auxiliary (non-safety) contact rated at 250V AC, 6A. T4SG-E series functions mirrored include, auto/manual reset, EDM, mute inputs, mute output and status.



RY4B – Additional contacts offer a more versatile safety relay option when integrating into more complex applications.

3 normally open safety relay contacts rated at 250V AC, 6A, and 1 normally closed auxiliary (non-safety) relay contact rated at 250V AC, 6A. T4SG-E series functions mirrored include, auto/manual reset, EDM, mute inputs, mute output and status.



RY4C – Combines RJ45 cable connection for simple plug and play connection of the T4SG-E series safety light curtain with additional contacts for a versatile safety relay option when integrating into more complex applications.



INTRODUCTION

3 normally open safety relay contacts rated at 250V AC, 6A, and 1 normally closed auxiliary (non-safety) relay contact rated at 250V AC, 6A. T4 Series functions mirrored include, auto/manual reset, EDM, mute inputs, mute output and status.

RY4A - TECHNICAL DATA

RY4A - SAFETY RELAY UNIT (020 – 005)

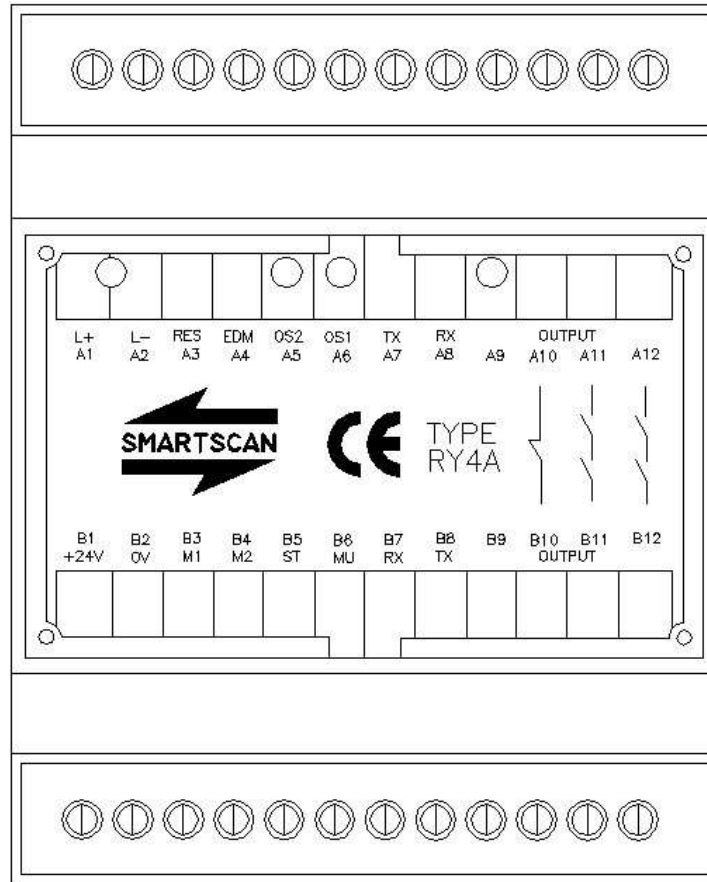

Status Indicators

Function	Colour	Status
Power	Red	LED ON when power ON
OSSD 1	Green	LED ON when input ON
OSSD 2	Green	LED ON when input ON
MON (EDM)	Amber	ON when EDM active

The RY4A is a relay module containing force guided relays to be used in safety applications where the relay monitoring, is provided by another safety component such as a light curtain or emergency stop relay.

RY4A - TECHNICAL DATA

Features – RY4A

- Dual safety electronic inputs for connecting the light curtain
- Safety relay contacts rated at 250V AC, 6A
- Mirrors the full functionality of the T4 light curtain
- Auxiliary relay (non – safety) rated at 250V AC, 6A
- Dedicated connections for the T4 series safety light curtain
- Contacts for External Device Monitor (EDM)
- LED status indicators
- Din rail mounting - 70mm enclosure
- Complies with BS EN 954–1 Category 4, EN ISO 13849-1 PL e, EN 61508 SIL3

Specification – Type RY4A

Response time	20ms max
Operating temperature	0° to 50°
Enclosure rating	IP40
Enclosure	70mm DIN rail mounting (H X W X D) 90 X 70 X 60 mm
Power supply requirement	24V DC \pm 10% regulated
Current consumption	200mA (NO LOAD)
Status indicators	LED's, Power On + Safety Input + EDM input
Classification	EN ISO 13849-1 PL e, EN 61508 SIL3

INPUTS

Dual Safety Electronic Inputs	24V DC = ON, 0V = OFF
EDM Contacts	Voltage free N/C contacts
Auxiliary Relay	24V DC = ON, 0V = OFF

OUTPUTS

Dual Safety Output Relays	2 x N/O fail safe relay contacts, each rated at 250V AC, 6A
Auxiliary Output Relay (Non - Safety)	1 X N/C 250V AC, 6A

Electrical connections - R4Y4A (See also Appendix 1)

Terminals A1 and A2 – Power supply input

Connect a suitably stabilised 24V DC power supply to terminals A1 = +24V DC and A2 = 0V DC. The current consumption of the R4Y4A with no load is 200mA maximum.

Terminal A3

Is not internally connected to the box.

It provides a junction point for terminating the user reset station to the light curtain reset. If the light curtain and R4Y4A relay are to be configured in 'auto-reset' mode connect a 24V DC supply to this terminal instead of through a normally-open contact reset switch.

Terminals A4 and A9 – External Device Monitor (EDM)

Terminal A4 (Receiver Yellow wire) is an EDM input from the light curtain to the R4Y4A relay.

Auxiliary normally-closed contacts in series from the external power switching devices are connected to terminal A9. Primarily used for monitoring an external device (if required), e.g. contactors, safety relays (FSD) final switching device. There is a yellow LED connected to A9 which may be used as an indicator for fault finding.

If terminal A9 is not being used for EDM then it must to be connected to +24V DC.

Terminals A5 and A6 – Safety inputs – Relay coil inputs to be connected to the device which will energise the internal force guided relays by applying 24V DC. A5 (Receiver Pink wire) and A6 (Receiver Grey wire) may be used for a light curtain input (OSSD1 and OSSD2) e.g. T4 series safety light curtain.

Terminals A7 and B7

Are internally connected contacts and may be used as link terminals.

When using the T4 Series light curtain A7 is used to connect the data link from the Receiver head, transmit signal (Blue wire). B7 is used to connect the data link from the Transmitter head, receive signal (Blue wire).

Terminals A8 and B8

Are internally connected contacts and may be used as link terminals. When using the T4 Series light curtain A8 is used to connect the data link from the Receiver head, receive signal (Red wire). B8 is used to connect the data link from the Transmitter head, transmit signal (Red wire).

Terminals A10 and B10

Auxiliary normally-closed relay contact output (non-safety) 250V, 6A.

Terminals A11 and B11 – safety output 1 switch contact

Connect terminals A11 and B11 to one channel of the machines stop circuitry, for example, via an external power-switching relay, directly to a safe PLC input or a machines final control element.

Terminals A12 and B12 – safety output 2 switch contact

Connect terminals A12 and B12 to one channel of the machines stop circuitry, for example, via an external power-switching relay, directly to a safe PLC input or a machines final control element.

If a single channel safety circuit is used link terminals B11 and A12. Terminals A11 and B12 are then connected to the machines safety circuit. Connecting in this way links safety output switch 1 and safety output switch 2 in a series configuration.

Terminals B1 and B2

Provides an auxiliary 24V DC supply. This may be used for connection of the 24V DC supply to the T4 Series light curtain. B1 = Receiver White wire, B2 = Transmitter White wire.

Terminals B3 and B4 -They are not internally connected. They can be used with the T4 Series light curtain to provide the junction point for Mute 1 and Mute 2 input connections from the light curtain to the user. B3 = Transmitter Green wire, B4 = Transmitter Yellow wire.

Terminal B5 - It is internally connected to the auxiliary relay coil input, which will energise the internal force guided relay by applying 24V DC. When using the T4 Series light curtain the status output from the light curtain is connected to this terminal to drive the auxiliary relay.

Terminal B6 - It is not internally connected. When using the T4 Series light curtain it is used as a junction point to provide the connection for the mute output signal to the user. B6 = Transmitter Grey Wire.

Terminal B9 - It is not internally connected. This connection may be used as a junction point for shield / earth connection for the light curtain.

RY4A - TECHNICAL DATA

RY4A Safety Relay - Terminal layout and legend.

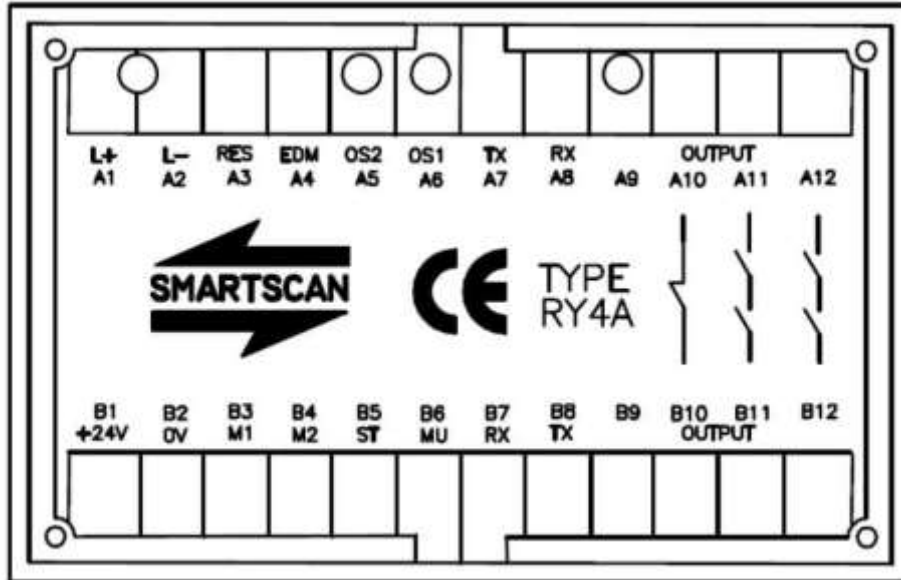

Note: Some outer legends refer to the application of the unit to a T4 light curtain and should be disregarded otherwise.

RY4A - TECHNICAL DATA

Internal Connections – RY4A

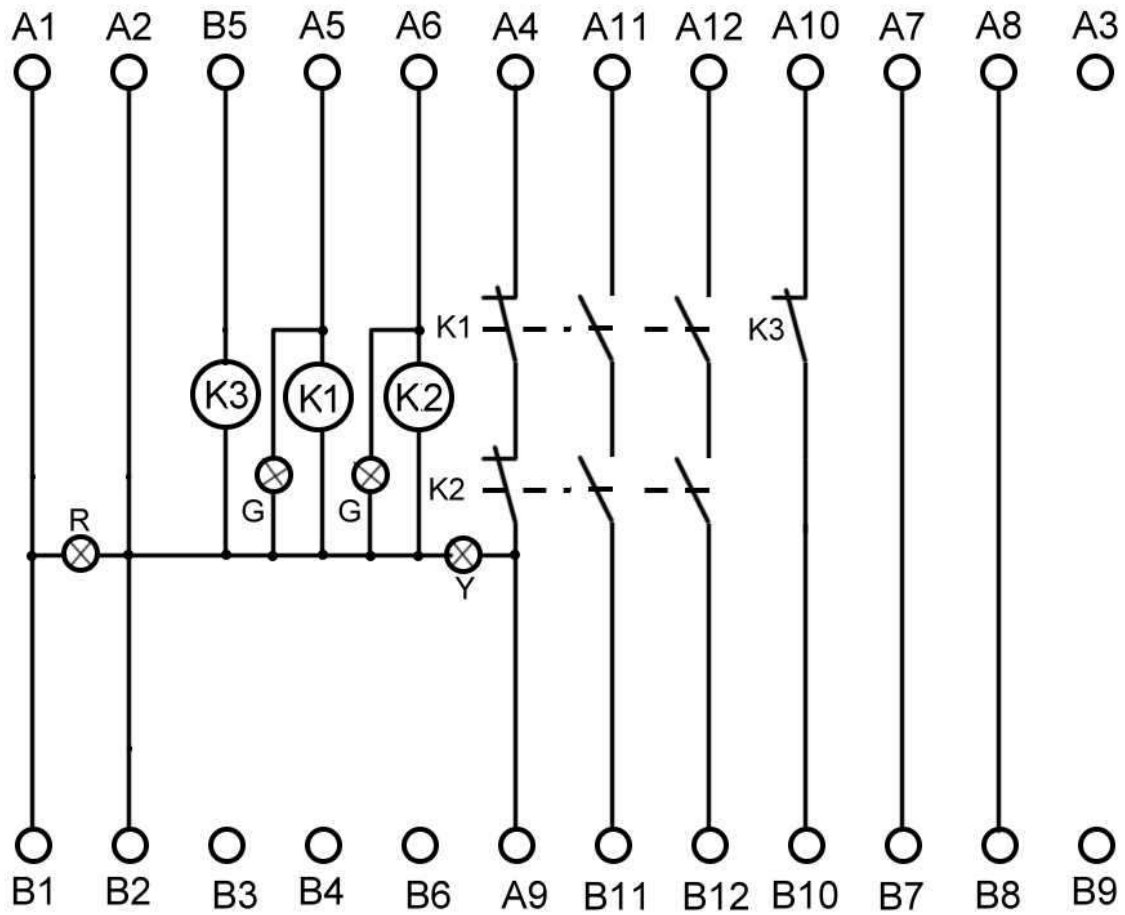

ACTIVATE

RED LED

YEL LED

K1

K2

K3

B1 OR A1 = 24V

A9 = 24V

A5 = 24V

A6 = 24V

B5 = 24V

RY4B - TECHNICAL DATA

RY4B - SAFETY RELAY UNIT (020 – 010)

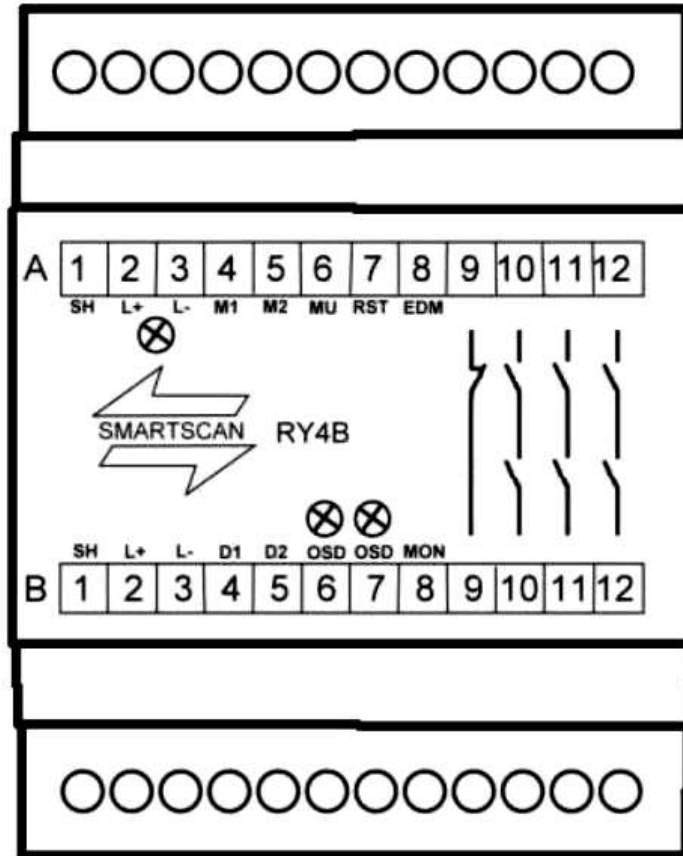

Status Indicators

Function	Colour	Status
Power	Red	LED ON when power ON
OSSD1	Green	LED ON when output 1 ON
OSSD2	Green	LED ON when output 2 ON

The RY4B is a relay module containing force guided relays to be used in safety applications where the relay monitoring, is provided by another safety component such as a light curtain or emergency stop relay.

RY4B - TECHNICAL DATA

Features – RY4B

- Dual safety electronic inputs for connecting the light curtain
- Safety relay contacts rated at 250V AC, 6A
- Mirrors the full functionality of the T4 light curtain
- Auxiliary relay (non-safety) rated at 250V AC, 6A
- Dedicated connections for the T4 series safety light curtain
- Contacts for External Device Monitor (EDM)
- LED status indicators
- Din rail mounting - 70mm enclosure
- Complies with EN ISO13849-1 PL e, EN61508, SIL3

Specification – Type RY4B

Response time	20ms max
Operating temperature	0° to 50° C
Enclosure rating	IP40
Enclosure	70mm DIN rail mounting (H x W x D) 90 x 70 x 60 mm
Power supply requirement	24V DC \pm 10% regulated
Current consumption	200mA (NO LOAD)
Status indicators	LED's, Power On + Safety Output
Classification	EN ISO13849-1 PL e, EN61508, SIL3

INPUTS

Dual Safety Electronic Inputs	24V DC = ON, 0V = OFF
EDM Contacts	Voltage free N/C contacts

OUTPUTS

Dual Safety Output Relays	2 x N/O fail safe relay contacts, each rated at 250V AC, 6A
Auxiliary Output Relay (Non - Safety)	1 X N/C 250V AC, 6A

Electrical connections - RY4B (See also Appendix 2 & 3)

Terminal A1

Provides connection for the supply shield / ground.

Terminals A2 and A3 – Power supply input

Connect a suitably stabilised 24V DC power supply to terminals A2 = +24V DC and A3 = 0V DC. The current consumption of the RY4B with no load is 200mA maximum.

Terminals A4 and A5

They are not internally connected. They can be used with the T4 Series light curtain to provide the junction point for Mute 1 and Mute 2 input connections from the light curtain to the user. A4 = Transmitter Green wire
A5 = Transmitter Yellow wire.

Terminal A6

It is not internally connected. For T4 Series light curtain it is used as a junction point to provide the connection for the mute output signal to the user. A6 = Transmitter Grey wire

Terminal A7

It is not internally connected to the box.

It provides a junction point for terminating the user reset station to the light curtain reset. If the light curtain and RY4B relay are to be configured in 'auto-reset' mode connect a 24V DC supply to this terminal instead of through a normally-open contact reset switch.

Terminals A8 and B8 - External Device Monitor (EDM)

Terminal B8 (Receiver Yellow wire) is an EDM input from the light curtain to the RY4B relay.

Auxiliary normally-closed contacts in series from the external power switching devices are connected to terminal A8. Primarily used for monitoring an external device (if required), e.g. contactors, safety relays (FSD) final switching device.

If terminal A8 is not being used for EDM then it must to be connected to +24V DC.

Terminals A9 and B9

Auxiliary (non-safety) normally-closed relay contact output 250V, 6A

Terminal A10 and B10 – safety output 1 switch contact

Provides a N/O safety relay output contact to be used in the safety circuit, e.g. connecting one channel of the machines stop circuit directly to a safety PLC input or a machines final control element.

Terminals A11 and B11 – safety output 2 switch contact

Provides a N/O safety relay output contact to be used in the safety circuit, e.g. connecting one channel of the machines stop circuit directly to a safety PLC input or a machines final control element.

Terminals A12 and B12 – safety output 3 switch contact

Provides a N/O safety relay output contact to be used in the safety circuit, e.g. connecting one channel of the machines stop circuit directly to a safety PLC input or a machines final control element.

Terminal B1

Provides connection for the shield / ground. This may be used for the T4 series light curtain. B1 = Receiver Shield and Transmitter Shield connection.

Terminals B2 and B3

Provides an auxiliary 24V DC supply. This may be used for connection of the 24V DC supply to the T4 Series light curtain.

B2 = Transmitter White wire and Receiver White wire, B3 = Transmitter Brown wire and Receiver Brown wire.

Terminal B4

Is not internally connected. This terminal is used to connect the data from the receiver head transmit signal (blue wire) and the data from the transmitter head receive signal (blue wire).

Terminal B5

T4 light curtain Data link connection is not internally connected. This terminal is used to connect the data from the receiver head receive signal (red wire) and the data from the transmitter head transmit signal (red wire).

Terminals B6 and B7 – Safety inputs – Relay coil inputs to be connected to the device which will energise the internal forcibly guided relays by applying 24V DC. B6 and B7 may be used for a light curtain input (OSSD 1 and OSSD2), e.g. T4 series safety light curtain. B6 = Receiver Grey wire, B7 = Receiver Pink wire.

Internal Connections - RY4B

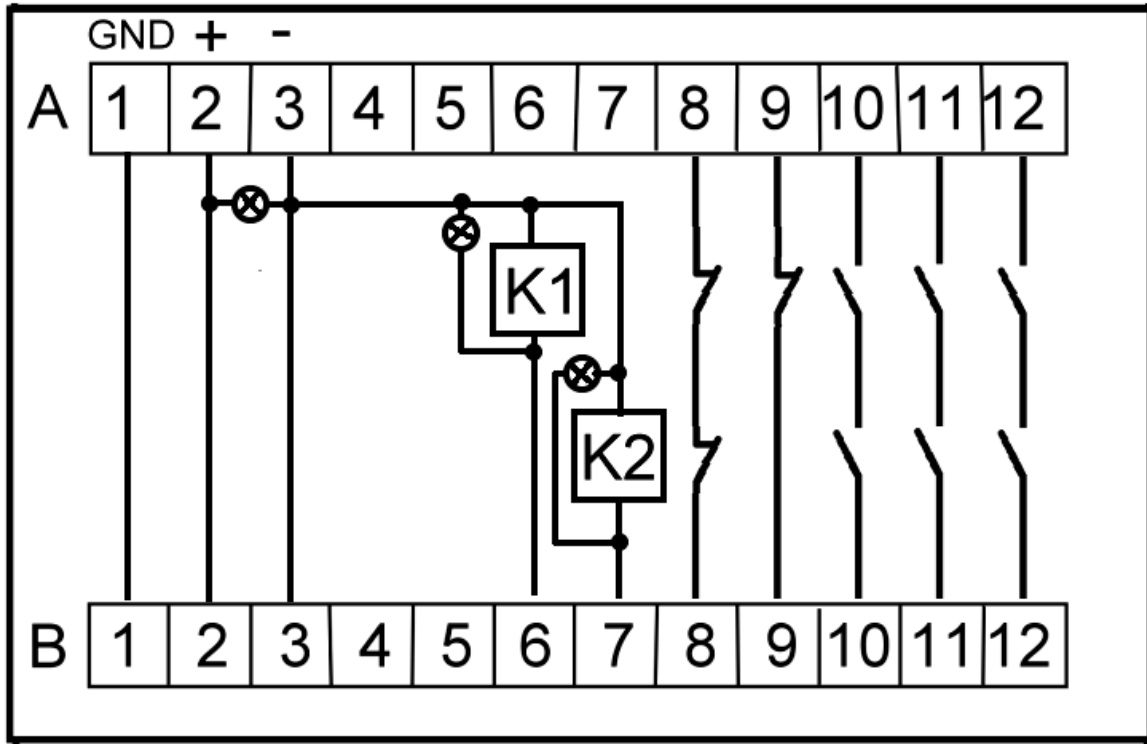

Note: If using the T4 Series safety light curtain with the RY4B the status wire (Pink) needs to be terminated to a terminal block if not being used.

RY4C - TECHNICAL DATA

RY4C - SAFETY RELAY UNIT (020 – 015)

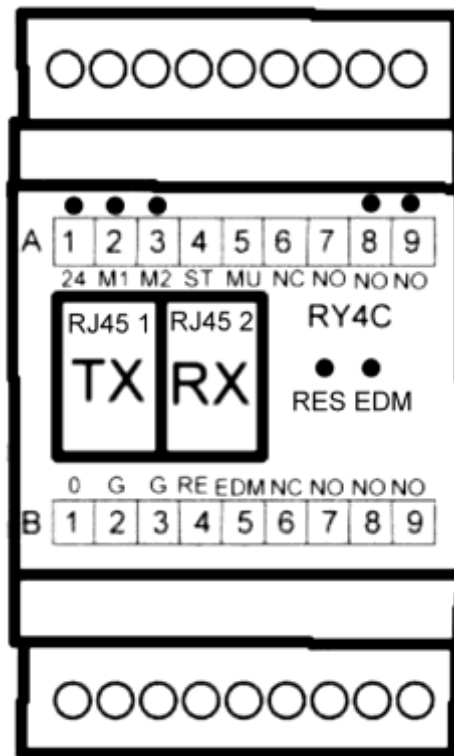

Status Indicators

Function	Colour	Status
Power	Red	LED ON when power ON
Mute input 1	Blue	LED on when mute requested
Mute input 2	Blue	LED on when mute requested
Reset Input	Green	LED on when reset requested
EDM input	Yellow	LED on when EDM is on
OSSD 1	Green	LED ON when output 1 ON
OSSD 2	Green	LED ON when output 2 ON

The RY4C is a relay module containing forcibly guided relays to be used in safety applications where the relay monitoring, is provided by another safety component such as a light curtain or emergency stop relay. It is fitted with RJ45 sockets connectors for quick connection of the T4SG-E light curtain.

RY4C - TECHNICAL DATA

Features – RY4C

- ❑ Quick-connect RJ45 connectors for T4 light curtain
- ❑ Safety Relay Contacts rated at 250V AC, 6A
- ❑ Mirrors the full functionality of the T4 light curtain
- ❑ Contacts for External Device Monitor (EDM)
- ❑ LED status indicators
- ❑ Din rail mounting - 52mm enclosure
- ❑ Complies with EN ISO 13849-1 PL e, EN 61508 SIL3

Specification – RY4C

Response time	20ms max
Operating temperature	0° to 50° C
Enclosure rating	IP40
Enclosure	52mm DIN rail mounting (H x W x D) 90 x 52 X 58 mm
Power supply requirement	24V DC ± 10% regulated
Current consumption	200mA (NO LOAD)
Status indicators	LED's, Power On + Safety Outputs Mute Inputs + Reset Input + EDM Input
Classification	EN ISO13849-1 PL e, EN61508, SIL3

INPUTS

EDM input	External device monitoring input (with T4)
Auxiliary relay	24V DC = ON OV = OFF

OUTPUTS

Dual Safety Output Relays	3 x N/O fail safe relay contacts each rated at 250V AC, 6A
Auxiliary output relay (Non – Safety)	1 X N/C, 250V AC, 6A

Electrical connections - RY4C (See also Appendix (4, 5 & 6))

Terminals A1 and B1 – Power supply input

Connect a suitably stabilised 24V DC power supply to terminals A1 = +24V DC and B1 = 0V DC. The current consumption of the RY4C with no load applied is 200mA maximum.

Terminals A2 and A3 – Mute Input signals

Connect suitable mute initiating signals to terminals A2 and A3 respectively. e.g. 24V DC = ON 0V DC = OFF.

The mute signals override the light curtains operation therefore the inputs should only be activated during safe periods of the machinery's operating cycle.

Terminal A4 – Status Output

The status output from the light curtain is connected to this terminal to drive the auxiliary relay. Terminal A4 may also be used to drive 30mA maximum load i.e. trip indicator.

Terminal A5 – Mute Output

It is internally connected to RJ45 (1) which is a mute output from the T4 Series safety light curtain. 24V DC = Mute On at 50mA maximum, 0V DC = Mute Off.

Terminals A6 and B6 – Auxiliary Output

Auxiliary (non-safety) normally-closed relay contact output 250V, 6A.

Terminals A7 and B7 – safety output 1 switch contact

Provides a N/O safety relay output contact, rated at 250V, 6A, to be used in the safety circuit, e.g. connecting one channel of the machines stop circuit directly to a safety PLC input or a machines final control element.

Terminals A8 and B8 – safety output 2 switch contact

Provides a N/O safety relay output contact, rated at 250V, 6A, to be used in the safety circuit, e.g. connecting one channel of the machines stop circuit directly to a safety PLC input or a machines final control element.

Terminals A9 and B9 – safety output 3 switch contact

Provides a N/O safety relay output contact, rated at 250V, 6A, to be used in the safety circuit, e.g. connecting one channel of the machines stop circuit directly to a safety PLC input or a machines final control element.

Terminal B2 - provides connection for the supply shield / ground.

Terminal B3 - provides connection for the shield / ground.

RY4C - TECHNICAL DATA

Terminal B4 – Reset Input

It is internally connected to RJ45 (2). This terminal is a user connection for resetting the T4 light curtain.

If the light curtain and RY4C relay are to be configured in 'auto-reset' mode connect a 24V DC supply to this terminal instead of through a normally-open contact reset switch.

Terminal B5 – EDM Input

This terminal is for the user EDM input to the RY4C.

Auxiliary normally-closed contacts in series from the external power switching devices are connected to terminal B5. Primarily used for monitoring an external device (if required), e.g. contactors, safety relays (FSD) final switching device. There is a yellow LED located on the front of the RY4C which may be used as an indicator for fault finding.

If terminal B5 is not being used for EDM then it must to be connected to +24V DC.

RY4C - TECHNICAL DATA

User connections to RY4C

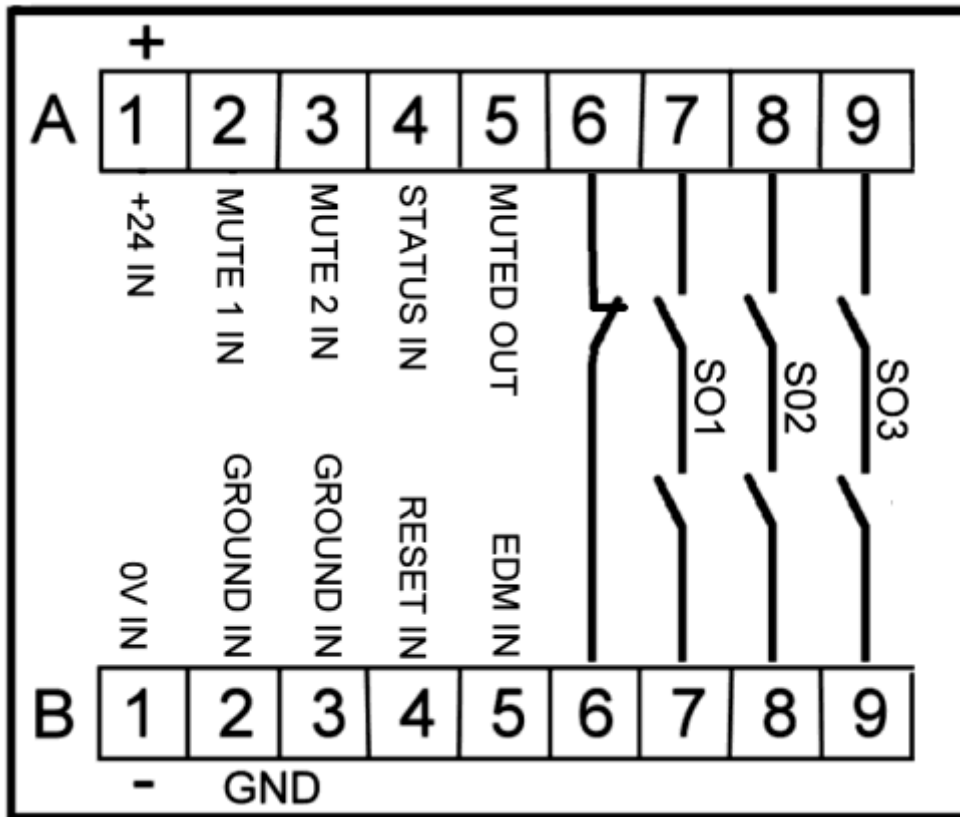

Internal Electrical Connections.

Note: The RJ45 connections are not shown in this diagram, see appendix 4, 5 & 6.

APPENDIX 1

RY4A Connection to T4SG-E series Safety Light Curtain

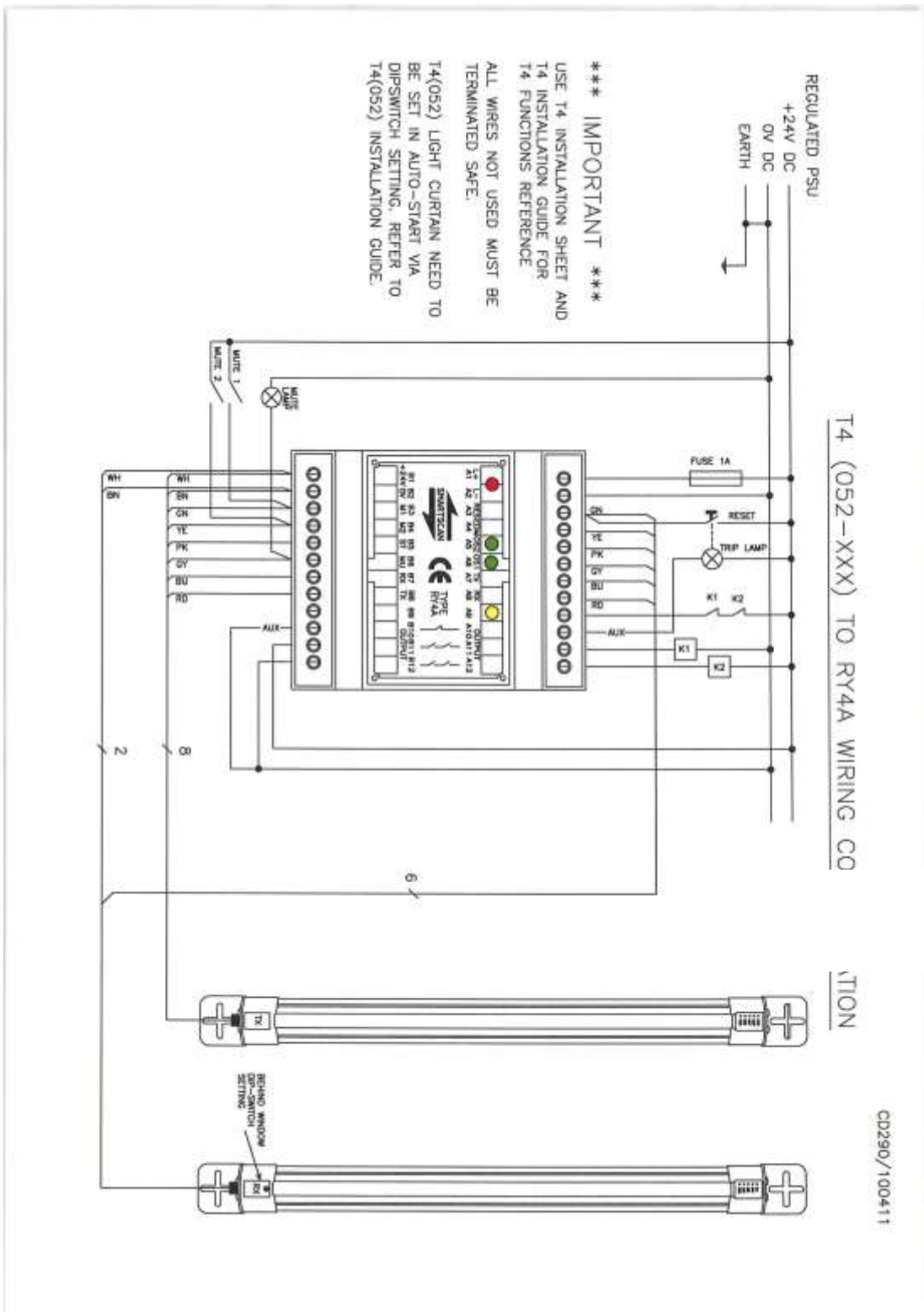

The RY4A provides connection points for the T4SG-E cables.
 Provides isolated 6A contacts as safety outputs.
 Provides isolated 6A contact for guard status.

APPENDIX 2

RY4B Connection to T4SG-E series Safety Light Curtain

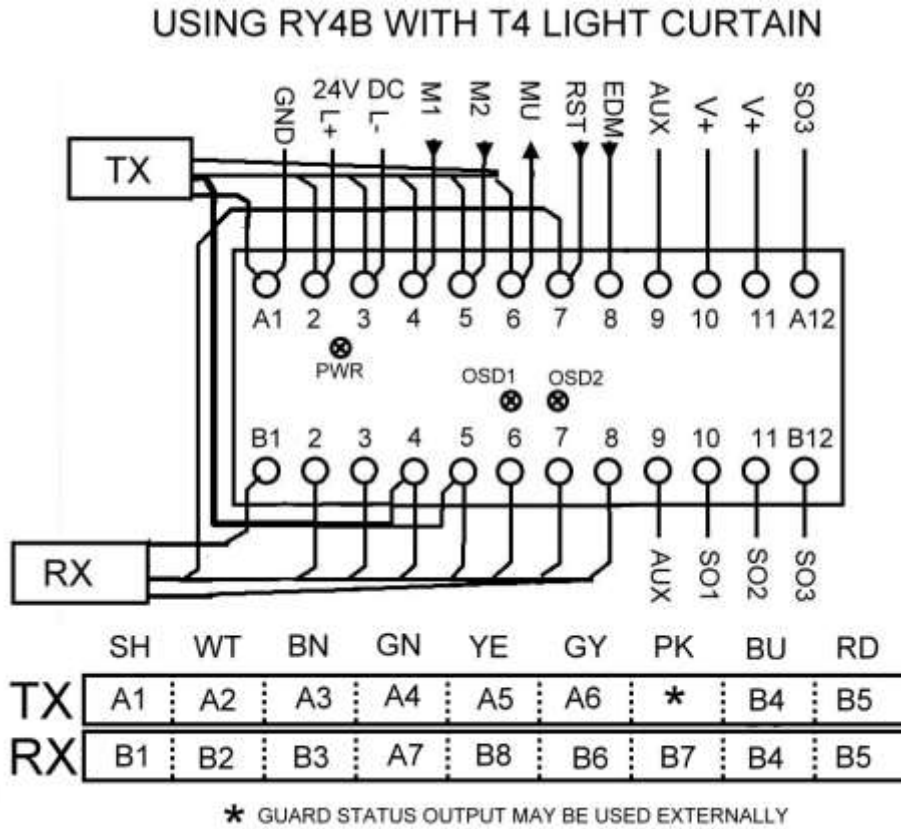

The RY4B provides connection points for the T4SG-E cables.
 Provides isolated 6A contacts as safety outputs.
 Provides isolated 6A contact for guard status

APPENDIX 3

RY4B – T4SG-E Interface to Safety Circuit Example

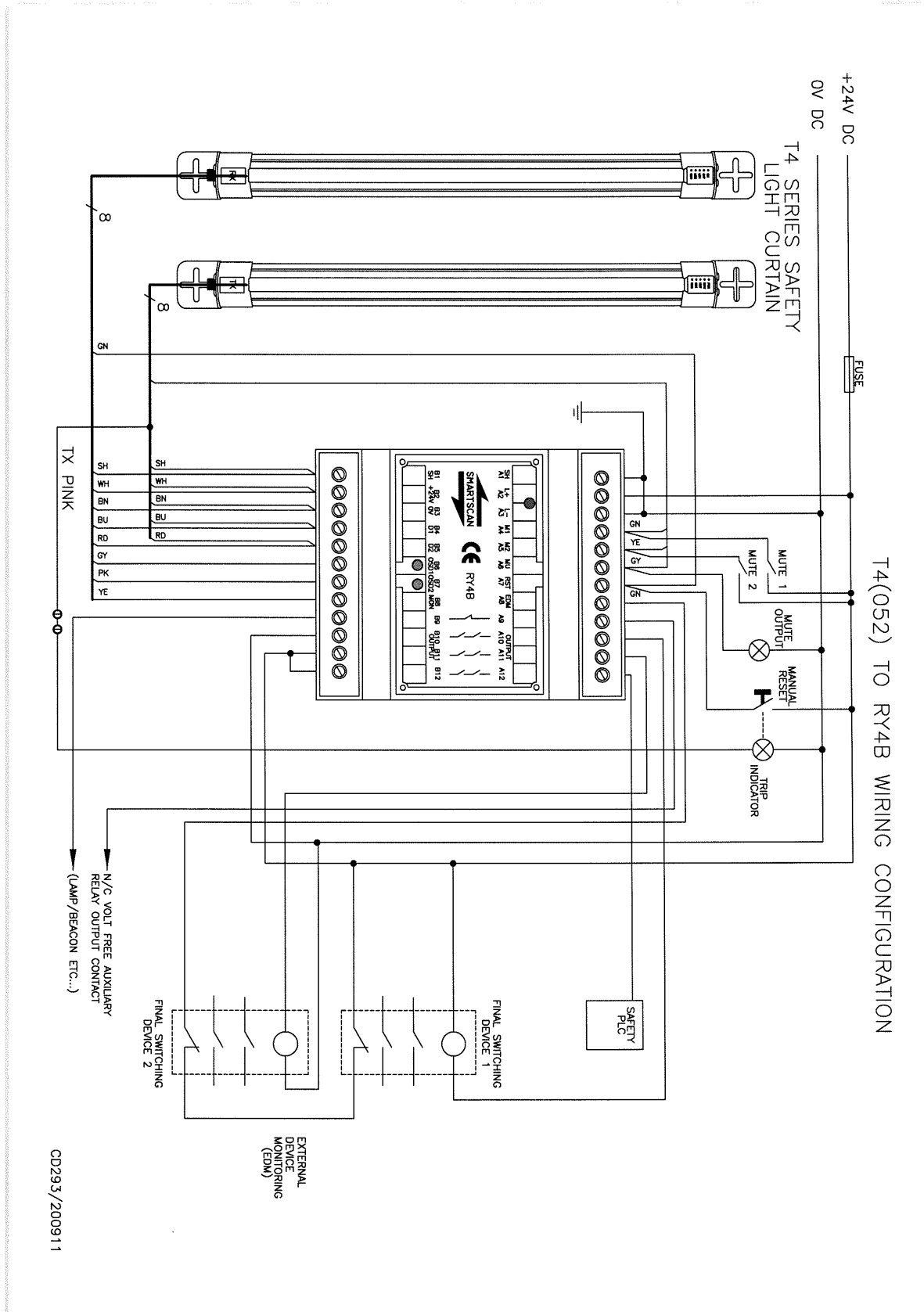

APPENDIX 4

RY4C Connection to T4SG-E Series Safety Light Curtain

USING RY4C WITH T4 LIGHT CURTAIN

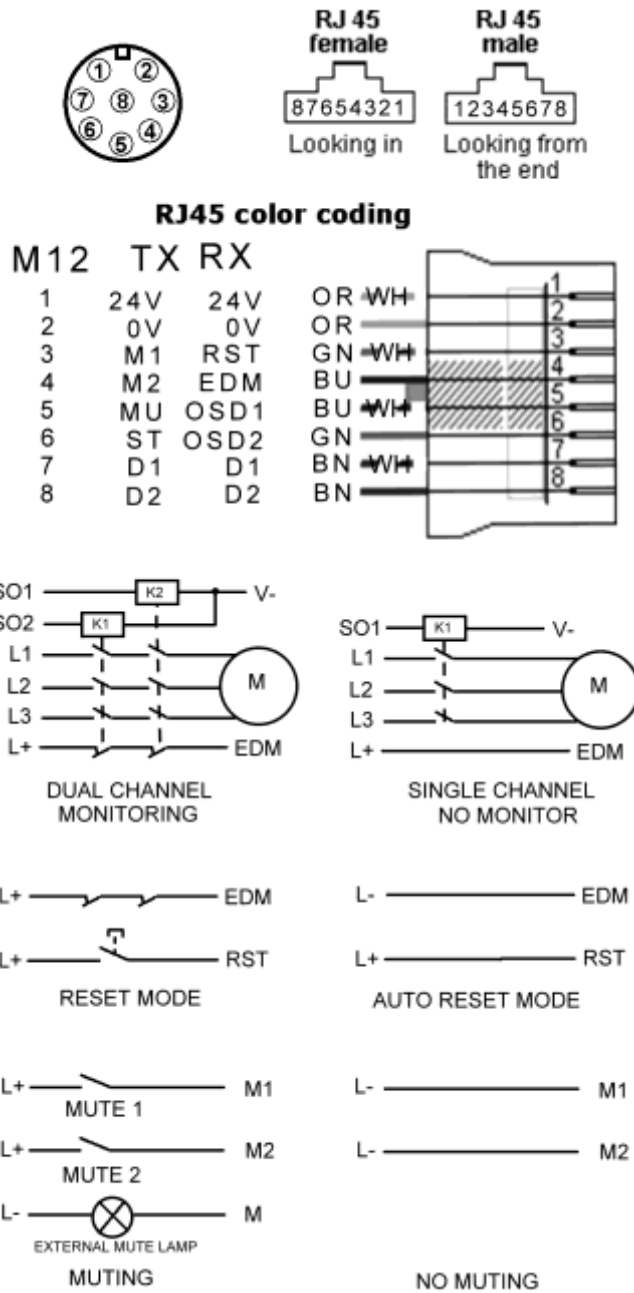

The RY4C provides connection points (RJ45) for compatible T4 cables. Provides isolated 6A contacts as safety outputs. Provides isolated 40ma electronic output for guard status.

APPENDIX 5

RY4C – T4SG-E Interface to Safety Circuit Example

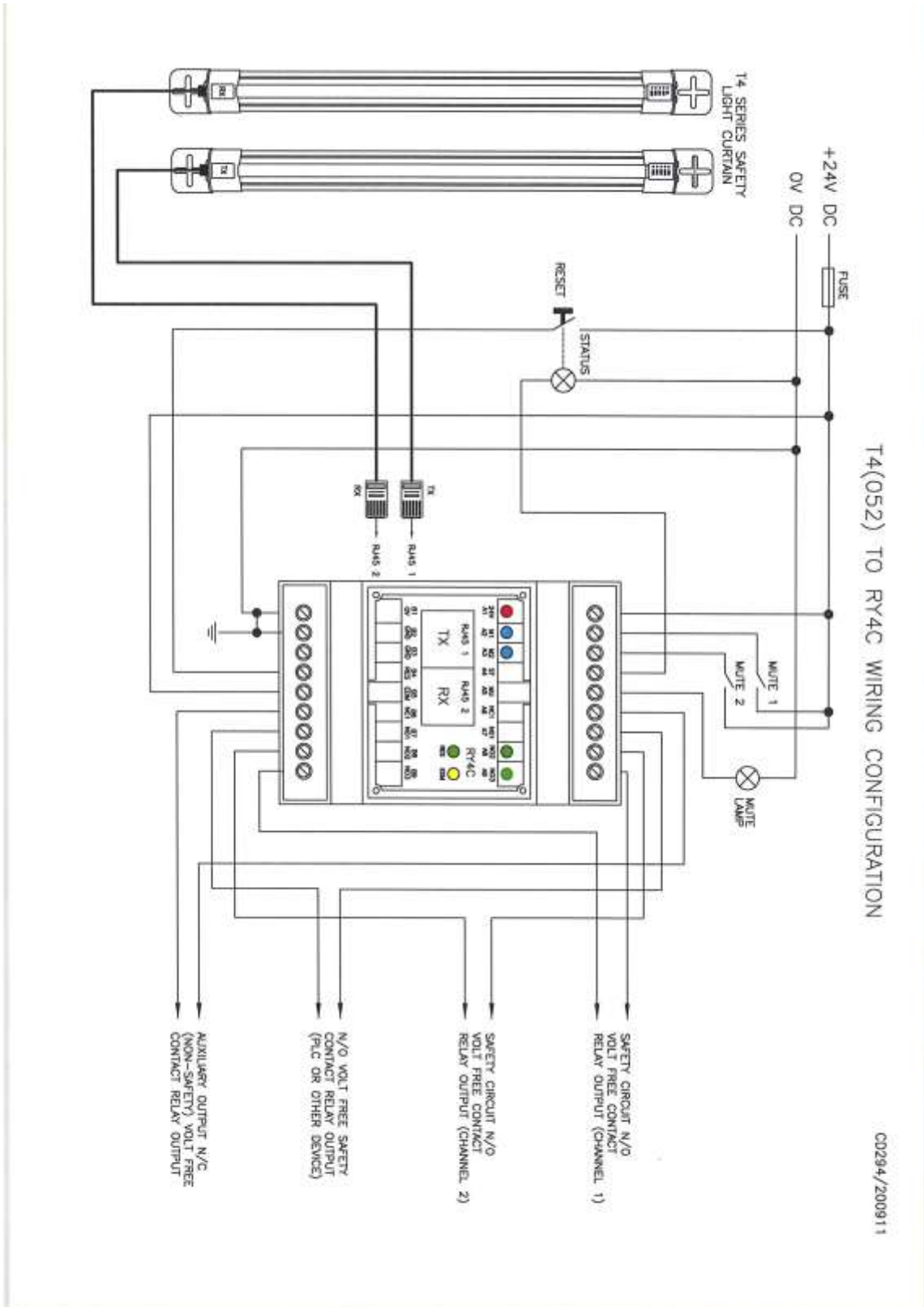

APPENDIX 6

RJ4C Connection to SL series Safety Light Curtain

USING RY4C WITH 1000+ LIGHT CURTAIN

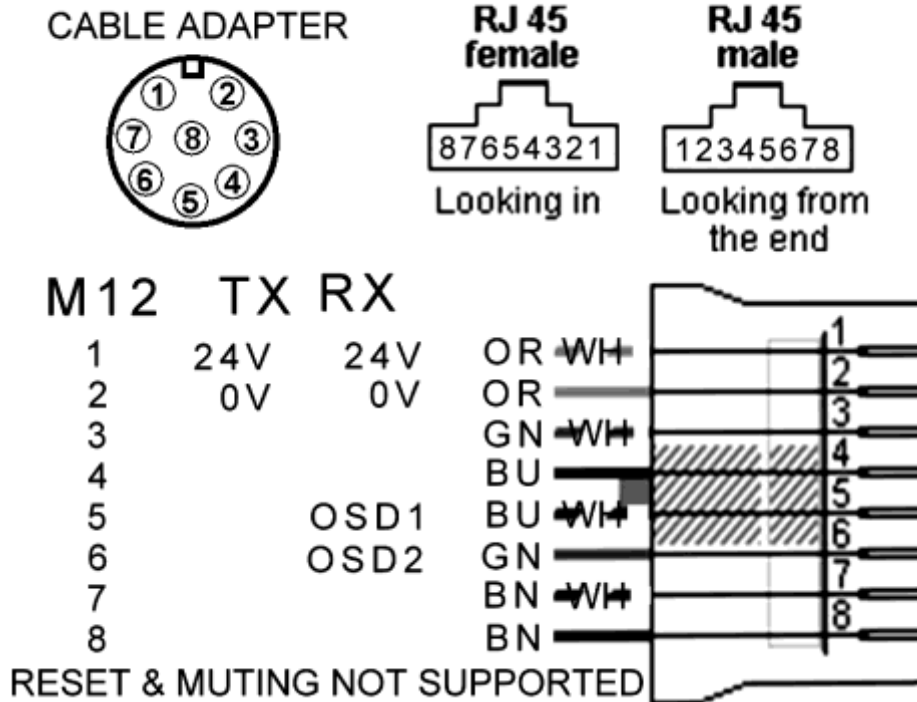

The RY4C provides connection points (RJ45) for compatible SL series cables.

Provides isolated 6A contacts as safety outputs.